

# Blamke®

## METALWORKER

### Contents

Before assembly, please check that you have all of the following parts. If any are missing, please contact our Part Department on 0208-988-7400

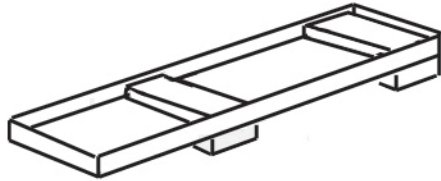

1 x Table Top/ Suds Tray assembly with drain plug.

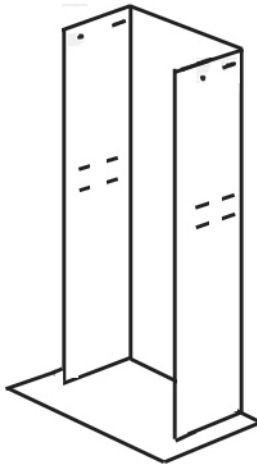

2 x End Unit

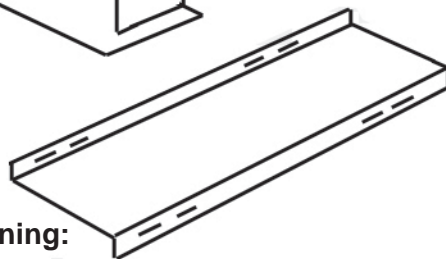

1 x Shelf Unit

Bag of fixings containing:

M10 Hex Head Bolts x 20

M10 Locknuts x 16

M10 Plain Washers x 36

M10 x 80 mm Hex Head Bolts x4

### Assembly

**NOTE:** All the component parts of this unit are drilled or pierced to ensure accurate assembly.

It will be easier to assemble this unit upside-down.

- 1) Lay the table top on a non-abrasive floor surface.
- 2) Position one End Unit around the outside of the angle plates on the underside of the Suds Tray and fix loosely with 4 x nuts, bolts and washers.

Repeat this procedure with the other end unit.

- 3) Locate and loosely fix the shelf unit in place using 2 x nuts, bolts and washers each side and at the front and rear.

Note that the turned down edge is at the front and the turned up edge at the rear.

- 4) Tighten all fixings before turning the assembled unit over.
- 5) The unit is now ready for floor fixing if required, by drilling through the base plates of each end unit.

## STAND FOR METAL LATHES CL430 & CL500M

PART NO: 7610315

### ASSEMBLY INSTRUCTIONS



# A SELECTION FROM THE VAST RANGE OF

# Clarke®

## QUALITY PRODUCTS



### AIR COMPRESSORS

From DIY to industrial, Plus air tools, spray guns and accessories.

### GENERATORS

Prime duty or emergency standby for business, home and leisure.

### POWER WASHERS

Hot and cold, electric and engine driven - we have what you need

### WELDERS

Mig, Arc, Tig and Spot. From DIY to auto/industrial.

### METALWORKING

Drills, grinders and saws for DIY and professional use.

### WOODWORKING

Saws, sanders, lathes, mortisers and dust extraction.

### HYDRAULICS

Cranes, body repair kits, transmission jacks for all types of workshop use.

### WATER PUMPS

Submersible, electric and engine driven for DIY, agriculture and industry.

### POWER TOOLS

Angle grinders, cordless drill sets, saws and sanders.

### STARTERS/CHARGERS

All sizes for car and commercial use.

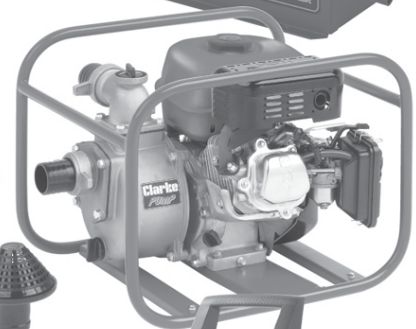
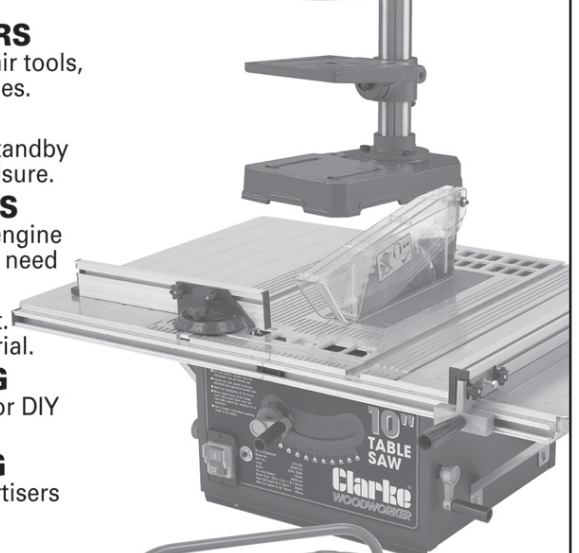

**PARTS & SERVICE: 0208 988 7400**

**E-mail: [Parts@clarkeinternational.com](mailto:Parts@clarkeinternational.com) or [Service@clarkeinternational.com](mailto:Service@clarkeinternational.com)**

**SALES: UK 01992 565333 or Export 00 44 (0)1992 565335**

**Clarke® INTERNATIONAL** Hemnall Street, Epping, Essex CM16 4LG  
[www.clarkeinternational.com](http://www.clarkeinternational.com)